

HEIGHT ADJUSTMENT: (regulation range: $\pm 5\text{mm}$)

1. Ease up on screws **1** for **every hinge** in door.
2. Unscrew the upper screw **2** for **every hinge** in door.
3. In case of very heavy door, we advise temporarily lighten door with for instance wedges.
4. Use allen wrench **3** to regulate with screw **4**. (one turn 360 degrees will change height by **1,25mm**)
It should be done for **every hinge** possibly **equal**.
5. After adjustment, screw tight screws **1** in all hinges.

ROLLER HINGE WR
HEIGHT REGULATION

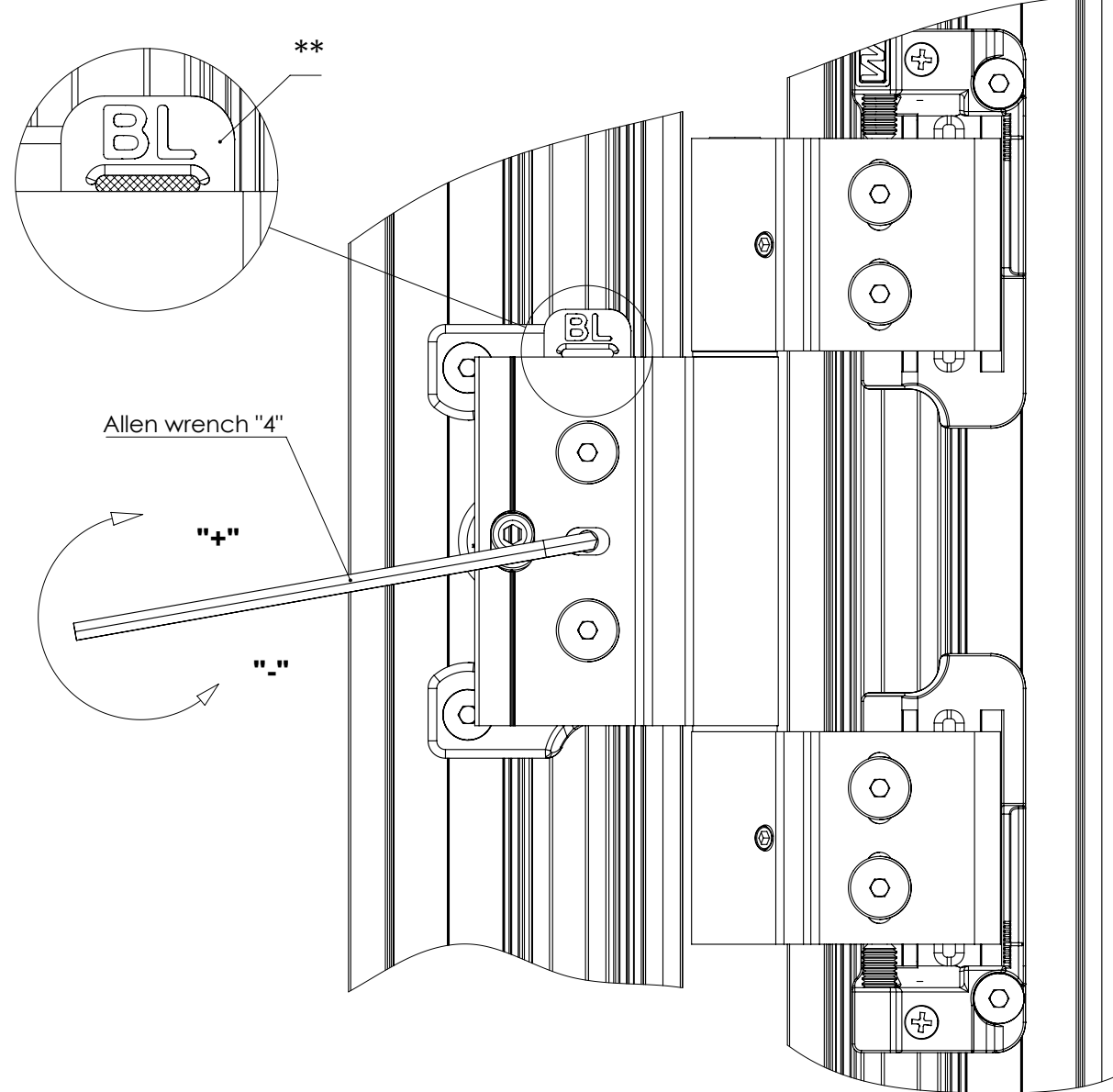
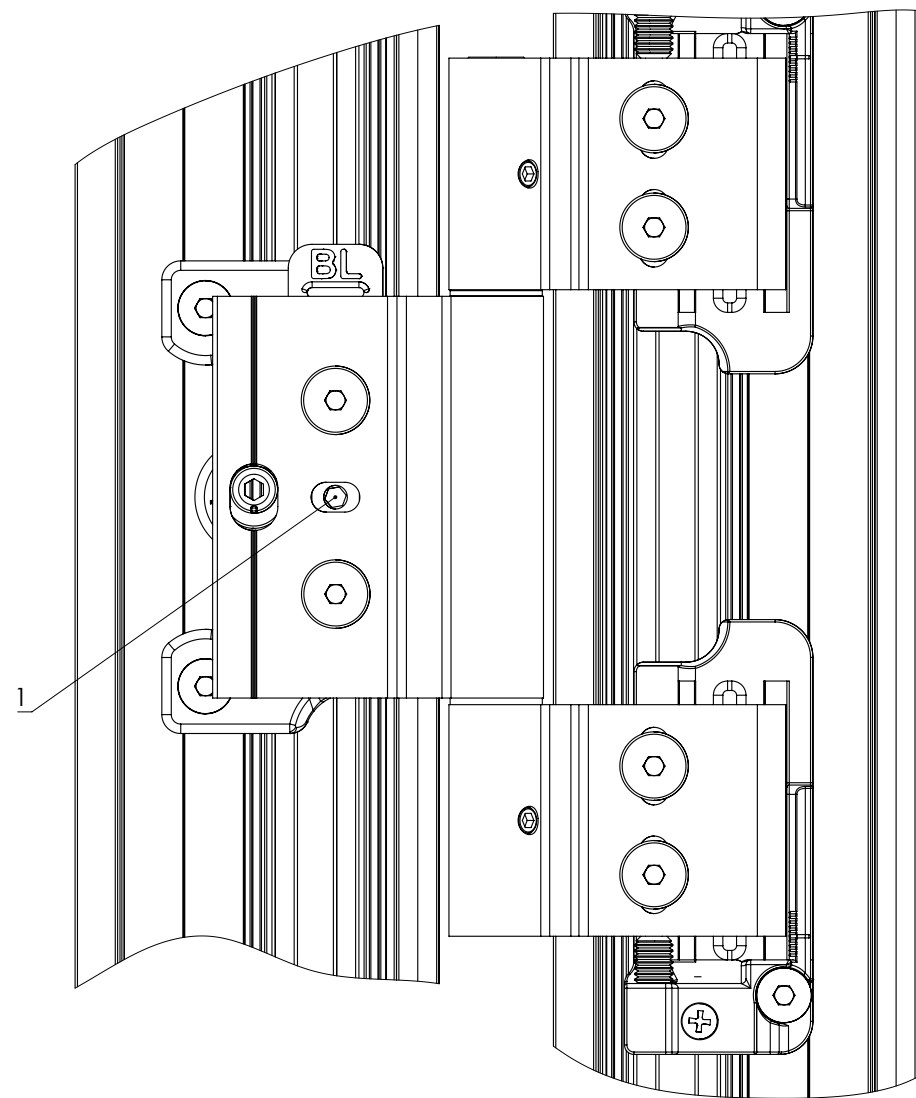

LEFT / RIGHT ADJUSTMENT: (regulation range: $\pm 2,5\text{mm}^*$)

1. Use allen wrench to regulate with screw 1. (one turn 360 degrees will change distance by **1,25mm**)

* - for systems with a **6mm** system slot, for a **5mm** gap due to thickness wings the possible adjustment value is **-1.5mm, + 2.5mm**

** - adjustment limiter at the negative direction: for systems in which the regulation range of the mechanism is larger than the system allows due to the thickness of the wings and the gap. If a further extended adjustment is necessary, remove the blockade with e.g. screwdriver, but taking responsibility for possible conflicts and bending.

ROLLER HINGE WR
LEFT / RIGHT REGULATION

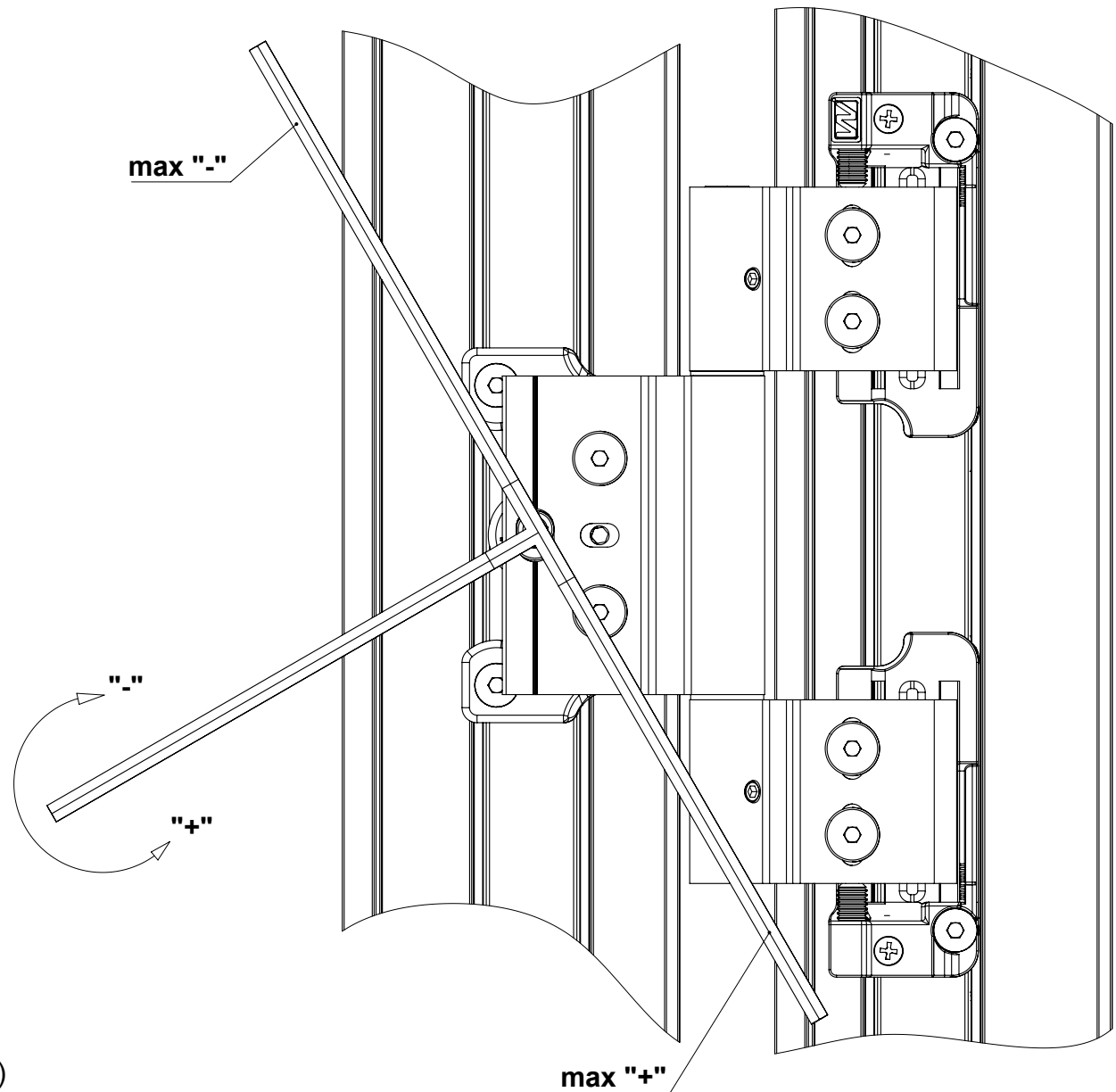
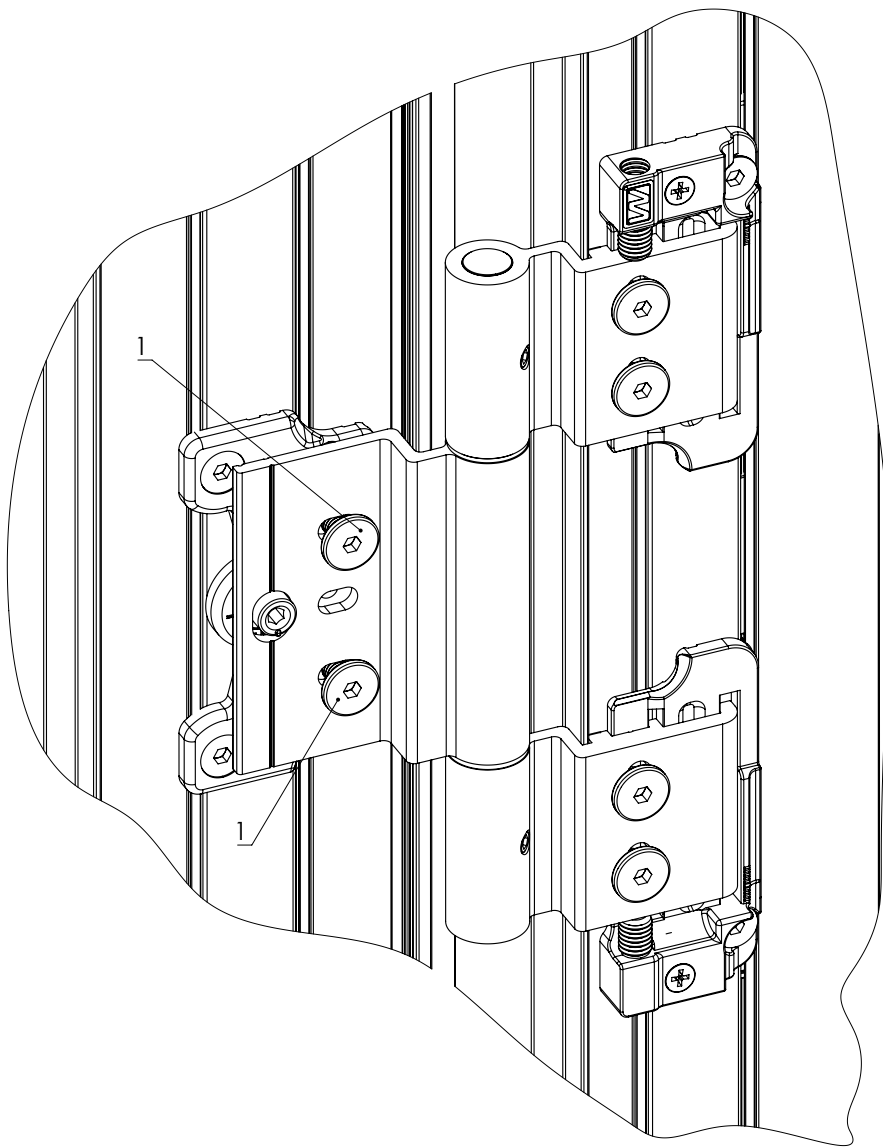

FRONT / BACK ADJUSTMENT: (regulation range up to $\pm 1,5\text{mm}^*$)

1. Door before the regulation should lightened.
2. Ease up on screws **1**.
3. Make adjustment by allen wrench "5" with the eccentric. Maximum value can be achieved by 90° turn.
4. After adjustment, screw tight screws **1**.

* - the real range could be smaller depending on distance near gasket in the aluminium systems

ROLLER HINGE WR
FRONT / BACK REGULATION